

NO	Q'ty	Material	Parts Name
1	1	ASTM A351 CF8M	Body
2	2	ASTM A351 CF8M	End cap
3	1	SUS304	Handle
4	1	SUS304	Gland
5	1	SUS316	Stem
6	2	PTFE	Seat Ring
7	1	SUS316	Ball
8	1	SUS304	Handle Nut
9	1	SUS304	Spring washer
10	1,2	PTFE	Thrust Washer
11	1	PTFE	Thrust Washer
12	2	PTFE	Seal Washer
13	4	SUS304	Bolts
14	4	SUS304	Nut
15	4	SUS304	Spring Washer
16	1	PLASTIC	HANDLE COVER
17	1	SUS304	LOCKING DEVICE

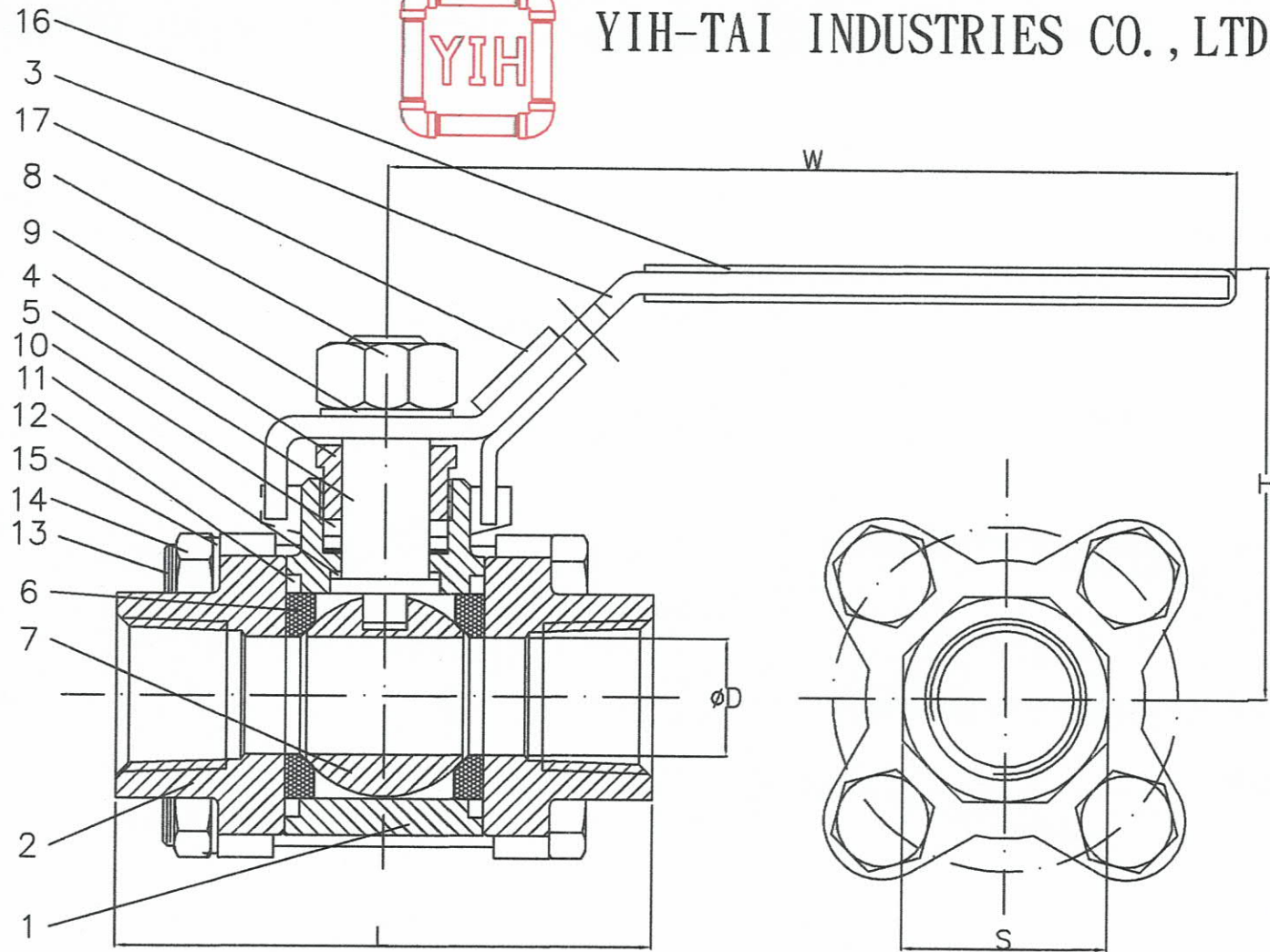

YIH-TAI INDUSTRIES CO., LTD.



#901 3PVBT(1000psi)

Name 3PVB 3- pc Ball Valve (1000psi) Drawing No (#901) 3PVBT

item Dim	1/4		3/8		1/2		3/4		1		1 1/4		1 1/2		2		2 1/2		3	
	INCH	MM	INCH	MM	INCH	MM	INCH	MM	INCH	MM	INCH	MM	INCH	MM	INCH	MM	INCH	MM	INCH	MM
D	0.43	11	0.50	12.7	0.63	16	0.77	19.5	0.98	25	1.26	32	1.50	38	1.97	50	2.56	65	3.15	80
S	0.87	22	0.87	22	1.06	27	1.30	33	1.58	40	1.97	50	2.21	56	2.76	70	3.43	87	3.94	100
L	2.17	55	2.17	55	2.52	64	2.91	74	3.31	84	3.78	96	4.13	105	4.84	123	5.98	152	6.85	174
W	3.80	96	3.80	96	4.25	108	4.25	108	7.01	178	7.01	178	7.01	178	7.01	178	9.61	244	9.61	244
H	1.70	43.2	1.70	43.2	2.05	52	2.15	54.5	2.68	68	2.87	73	3.05	77.5	3.43	87	4.72	120	5.16	131
CV	6		7		10		25		35		46		80		110		310		360	